

TUBO | X-PERT RT



1985 - 2015



TUBO | X-PERT RT



Commercial Systems



TUBO | X-PERT RT

Increased power,
smaller in size.

Medium- and large-sized buildings have special needs regarding the installation and use of a central vacuum system: more power, contemporary design and small size.

The X-PERT RT central vacuum unit is the result of the desire to create an even more versatile product, to be used for both residential and service sector applications.

A single range able to meet the needs of an informed and demanding market, which only Aertecnica quality is able to satisfy.

The Tubò system has solutions for every sector, from residential to commercial.



TUBO | X-PERT RT

It provides aspiration everywhere.

X-PERT RT is the new range of central vacuum units by Aertecnica, created to offer an even broader and more versatile line of products.

X-PERT RT is designed to be used as an alternative to the conventional range for residential applications where higher levels of performance and power are required.

X-PERT RT is used in the residential advanced or tertiary sector. X-PERT RT offers the same features as central vacuum units designed for the service sector, but with the compact size and pleasant appearance of residential sector units.

X-PERT RT offers excellent levels of performance and is built in compliance with Aertecnica's quality standards.

X-PERT RT is therefore the product bridging the gap between the residential and tertiary sectors, capable of adapting to different needs and will be used in: hotels, Bed & Breakfast, villas, gyms, offices, restaurants, clinics, etc., where at most 2 simultaneous operators are required and the surfaces are not too extensive.

Since it is such a versatile product, we always recommend that you seek advice from our technical Office, or one of our sales consultants for a safe and correct choice.

X-PERT RT is a multifunctional range, suitable for demanding customers that choose and appreciate the quality of Aertecnica products.



Model	RT1A
Code	CIRT10A
Description	2.2 kW 380V three-phase with standard APF system*
Operators	1

Model	RT2MA
Code	CIRT20MA
Description	2.6 kW 230V SINGLE PHASE with standard APF system*
Operators	1-2

Model	RT2A
Code	CIRT20A
Description	2.6 kW 380V three-phase with standard APF system*
Operators	1-2

*In the event that the vacuum system is activated during the scheduled filter self-cleaning cycle (APFSystem), the central vacuum unit restart time will be approximately 30 seconds. APFSystem, Filter Self-Cleaning System, patented (Europe Patent Pending no. 06793421.6)



X-PERT RT technical table

Model		RT1A	RT2MA	RT2A
Trade code		CIRT10A	CIRT20MA	CIRT20A
No. of operators at the same time		1	2	2
Self-cleaning system (APF System)*		YES	Yes	YES
Inverter		NO	YES	YES
Power supply	Volt (V)	380 - 400	220 - 240	380 - 400
Motor power	Watts (W)	2,200	2,600	2,600
Frequency	Hz	50 - 60	50 - 60	50 - 60
Maximum absorption:	A	6.5	11.2	6.5
Motor rpm	rpm	2,900	3,500	3,500
SOFT START		No	YES	YES
Vacuum Sockets power supply voltage	Volt (V)	12	12	12
Air flow rate		300	360	360
Maximum vacuum	mbar	392	392	392
Filtering surface	cm ²	20,000	20,000	20,000
Filter cartridge material		POLYESTER	POLYESTER	POLYESTER
Dust container capacity	litres	66	66	66
Dust inlet diameter	mm	80	80	80
Air exhaustion diam.	mm	80	80	80
Vacuum Setting Adjustment	cm	Manual provided**	Electronic	Electronic
Height	cm	161***	161***	161***
Diameter	cm	46	46	46
Mass	kg	99	100	100
Noise	db	<70	<70	<70
Compatibility with CMT800 Panel (in Modbus mode)		YES	YES	YES

* In the event that the vacuum system is activated during the scheduled filter self-cleaning cycle (APF System), the central vacuum unit restart time will be approximately 30 seconds.

** Ø63 compensation valve provided

*** Check central vacuum unit installation dimensions in the technical manual

TUBO | X-PERT RT



Main features

- Installation and set-up system employing Plug & Play technology. Rapid connection is made possible thanks to the electrical connectors and terminals included in the installation set. This eliminates any possible errors with electrical connections.
- All models are provided complete with the APF filter self-cleaning System (a filter self-cleaning system patented by Aertecnica).
- Filter cartridge with large filtering surface area: 20,000 cm², made from washable polyester.
- Electronic vacuum regulation: RT2A and RT2MA models only.
- Instant AVI display.
- Compensation Valve included: RT1A model only.
- Small size with high levels of performance.
- Ergonomic and easy-to-use dust container release handle.
- 66 Lt. Dust Container with "Quick Scroll" system with wheels



TUBO
CENTRAL VACUUM SYSTEMS

Ideal for:

X-PERT RT is the central vacuum unit which bridges the gap between the residential and tertiary sector. It can be installed in different kinds of structures:

- Hotels: even with a number of floors, when you decide to use one central vacuum unit on each floor.**
- Bed & Breakfast*
- Villas*
- Gyms*
- Offices*
- Restaurants*
- Clinics*
- etc...

* All these facilities must require a maximum of 2 operators working at the same time.

** In the case of multi-storey Hotels, max. 2 operators working concurrently on the same floor.

Ideal fusion ... inside and out!

a

- Air expulsion
- Air flow division plate for motor cooling
- General on/off switch
- Electronic Card
- Temperature sensor
- Control Panel with AVI Display
- Inverter (only on RT2A - RT2MA models).
Compensation valve for pressure adjustment only provided with model RT1A
- MODBUS communication system
- Side channel blower (Motor)

b

- APF System*
- Washable polyester filter cartridge
- Left/right reversible dust inlet
- Filter cartridge fastening knob
- Handle for opening/closing of "Quick Scroll" dust container

c

- Deflector cone with seal
- Bag Tensioner
- Dust collection bag
- "Quick Scroll" dust container with wheels
- Anti-vibration base

* In the event that the vacuum system is activated during the scheduled filter self-cleaning cycle (APF System), the central vacuum unit restart time will be approximately 30 seconds. APF System, Filter Self-Cleaning System, patented (Europe Patent Pending no. 06793421.6)



The heart of the system

- 1 **Air expulsion**
- 2 **Electronic Card:** This circuit board is the heart of the whole system, it drives the motor start-up and the AVI display. A special programme communicates with the display, which uses icons and parameters to signal the operational state of the central vacuum unit.
- 3 **General on/off switch:** The on/off switch allows you to switch the central vacuum unit ON or OFF.
- 4 **Air flow division plate for motor cooling**
- 5 **Temperature sensor:** This monitors the operation of the central vacuum unit and intervenes in the event of malfunctions caused by incorrect usage.
- 6 **Side channel blower (Motor):** Protected, insulated and highly professional, this part ensures high performance and a long life for the central vacuum unit which will provide continuous work for a long time. 100% Italian technology.
- 7 **Control Panel with AVI Display:** (Instant view) Positioned on the front of the unit. It features state-of-the-art design, with icons and parameters that are very simple and easy to understand; the control panel also consists of a keypad for easy browsing and control of the various operating parameters of the central vacuum unit.
- 8 **Inverter (only on models RT2A-RT2MA) - Compensation Valve for pressure adjustment only provided with model RT1A.** The inverters on models for 2 operators (RT2A and RT2MA) and the compensation valve included on the RT1A model for 1 operator are the protection system for central vacuum units which avoids excessive pressure levels and protects the life of the motor.
- 9 **MODBUS communication system:** A generic ModBus protocol has been implemented in the central vacuum unit, which allows it to be interfaced with the most common home automation systems.



Vacuum everywhere

- 10* **APF System***: The APF system (Self-cleaning filter) noticeably reduces filter maintenance, and allows the central vacuum unit to operate at optimal levels for longer, thanks to a filter that is always clean. APF System is an Aertecnica patent. And in the event that the vacuum system is activated during the scheduled filter self-cleaning cycle (APF System), the central vacuum unit restart time will be approximately 30 seconds.
- 11 **Washable polyester filter cartridge**: made of highly efficient filtering material which is washable. Equipped with an alignment system, which makes for easier installation and maintenance.
- 12 **Left/right reversible dust inlet**: a big plus for the installer. Ensures maximum flexibility of assembly of the central vacuum unit in every position, making installation faster.
- 13 **Handle for opening/closing of "Quick Scroll" dust container**: Practical and functional closing and opening system. An advantage for the user who will be able to easily move the dust container for easy and quick maintenance.

*APF System*** standard fitting on all models

The central power unit is equipped with a self-cleaning system (Aertecnica patent) which allows the dust removal through vibration filter. This extends the regeneration/replacement time of the filter cartridge.

APF SELF-CLEANING ACTIVATION MODE

The daily self-cleaning process can be set according to one of the procedures below:

- 0 - APF disabled
- 1 - Activation of a daily APF cycle
- 2 - Activation of two daily APF cycles
- 3 - Activation of three daily APF cycles
- 4 - 30 minutes after the central power unit is turned off the APF cycle starts automatically.
- 5 - 30 minutes after the central power unit is turned off, the APF automatically starts, only if the 30% saturation threshold of the filter is exceeded.
- 6 - Manual activation of the APF cycle from the keyboard.



* By default, the APF is set to mode 4, the duration of each APF cycle is 5 minutes and the APF is always active in manual mode. In the event that the vacuum system is activated during the scheduled filter self-cleaning cycle (APF System), the central vacuum unit restart time will be approximately 30 seconds. While the unit is running, the APF cannot be activated and the wording APF appears on the AVI display followed by the number that corresponds to the mode enabled.

APF System, Filter Self-Cleaning System, patented (Europe Patent Pending no. 06793421.6)



X-PERT RT not only for professionals

- 14 **Deflector cone with seal:** is inserted inside the dust container. Thanks to its new deeper shape, more dust can be collected without it spreading throughout the machine body. The filter is kept clean in this way, providing longer-lasting performance.
- 15 **Dust collection bag with tensioner:** replacing the dust collection bag on the X-PERT RT is quick and easy. Its large size contains a greater quantity of dust, thereby reducing the number of maintenance tasks.
- 16 **"Quick Scroll" dust container with wheels:** The container is made of highly durable metal. The wheels and the Quick Scroll system allow you to move the central vacuum unit easily, which simplifies the maintenance.
- 17 **Anti-vibration base:** This stabilises the central vacuum unit and eliminates motor vibration when the vacuum unit is in operation.

Opening/Closing of "QUICK SCROLL" Dust Container:

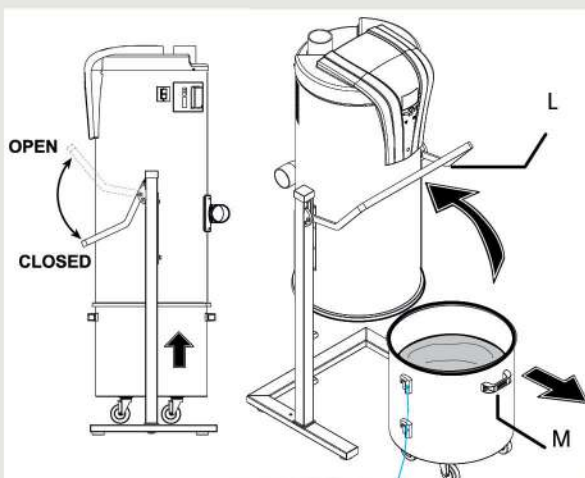

Open

Turn the special handle (L) upwards and remove the QUICK SCROLL dust container using the carrying handle (M).

Closing

Put the container inside the frame so that the two hooks (S) of the container are flush on the two pins (P) on the left and right side of the frame.



Control Panel

The central vacuum unit has a control panel that includes an AVI display (immediate display) and a built-in keyboard to navigate and control the various central vacuum unit operating parameters.

AVI Display

The alpha-numeric display is controlled by the electronic card and is used to control the following parameters:

CLEAN BAG FILLING

This detects the filling level of the dust container and displays 4 different levels.

FILTER CARTRIDGE SATURATION

This detects the saturation level of the filter cartridge and displays 5 different levels.

OPERATING VACUUM RANGE

This displays the vacuum level at which the central power unit is operating:

LO (low) - OK (correct) - HI (High)

OPERATING VACUUM

This displays the operating vacuum level of the central power unit

MOTOR POWER PERCENTAGE

This displays the motor power percentage that is adjusted on the hose with the speed variator.

TOTAL MOTOR HOURS

This displays the total hours of use of the central power unit.

MOTOR TEMPERATURE

Displays the motor temperature.

MOTOR TEMPERATURE ANOMALY/LOCK

Displays an anomaly/lock due to the engine temperature exceeding 80°C.

MAXIMUM USE TIME ANOMALY/LOCK

Displays an anomaly/lock due to continuous use of the central power unit for 30 minutes.

UNIT ANOMALY

This provides a generic report for a malfunction on the central vacuum unit



KEYBOARD

The keyboard has 4 buttons that are used to perform the following functions:

- **START BUTTON**
The START button activates the central vacuum unit. The arrow  is used to navigate the upper menu in the programme.
- **STOP BUTTON**
The STOP button turns off the central unit. The arrow  is used to navigate the lower menu in the programme.
- **RESET/ESC BUTTON**
The central unit can be reset after a block or anomaly by pressing the button. When you enter the programming mode, press ESC to exit the parameter.
- **MENU/OK BUTTON**
If the button is pressed, it displays the central power unit's maintenance cycles. When you enter programming mode the OK button allows you to enter the parameter.

Dynamic Control Display Everything Under Control (optional I Code CMT800)

Code CMT800 Dynamic Control Display (electric wall plate not included)

The Dynamic Control Display is Aertecnica's answer to home automation and it can be placed in any part of the building.

The display is aesthetically similar to any other electrical switch, allowing for perfect architectural integration.

Dynamic Control Display, Code CMT800, is an instrument that provides clear information that is easy to understand. It uses a set of icons and parameters that instantly report the operational status of the machine. It is equipped with a Reset function that automatically resets the system without having to access the machine in the event of a malfunction. The Dynamic Control Display automatically configures itself to the type of central vacuum unit it is connected to. Dynamic Control Display is an optional of the Tubò system.

- a** Dust collection Bag saturation
- b** Filter cartridge saturation
- c** Central vacuum unit ON indicator
- d** Operating + Reset buttons
- e** Display of operating parameters
- f** Pressure and maximum temperature gauge



The Dynamic Control Display Code CMT800 communicates with the X-PERT central unit in Modbus mode, already set by default by the manufacturer.

For the connection between the X-PERT central vacuum unit and the Dynamic Control Panel, you require a power line cable with a section of not less than 2 x 0.25 mm.

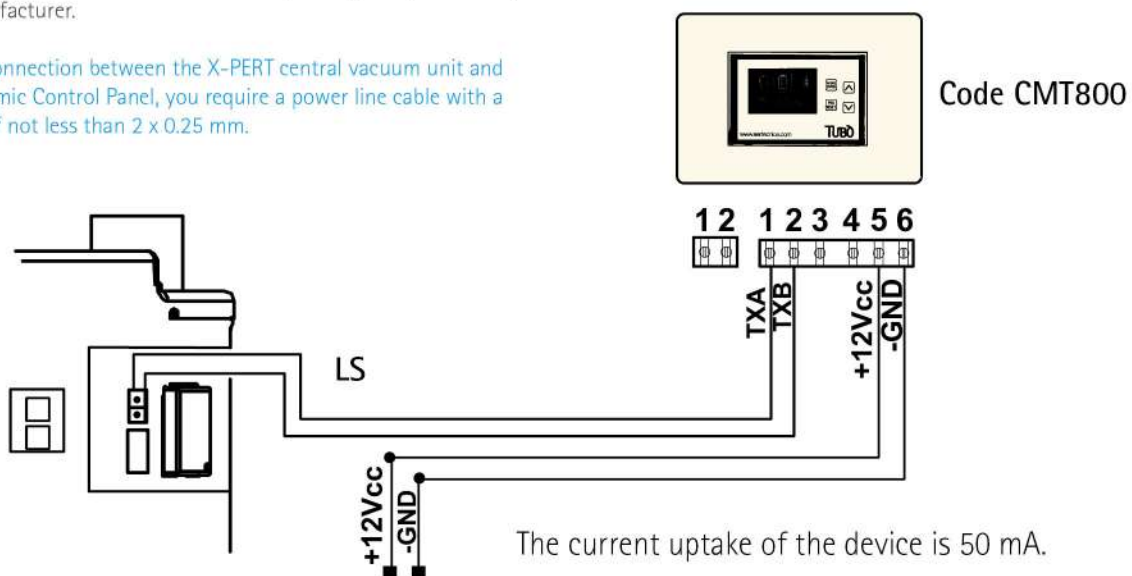



Address: Hastings 4120, New Zealand
Phone: 027 69 287 00
Email: info@tubo.co.nz
www.tubo.co.nz



1985 - 2015

