

TUBO

the advanced
vacuum system.

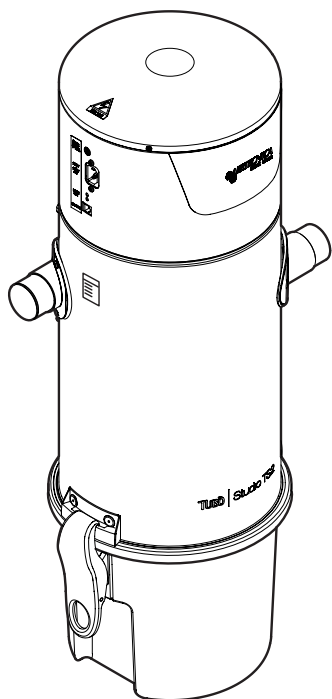

USE AND MAINTENANCE MANUAL



STUDIO TS

CENTRAL POWER UNIT



STUDIO TS

USE AND MAINTENANCE MANUAL

INDEX

GENERAL INFORMATION

- 2 General warnings
- 2 Warranty
- 3 Safety
- 3 Certifications
- 3 Identification
- 3 Manufacturer
- 4 Identification plate
- 4 TUBO system description
- 5 Part description
- 6 Technical features
- 6 Handling the packaging
- 6 Opening the packaging
- 7 Foreseen use
- 7 Incorrect use
- 7 Starting/stopping

MAINTENANCE

- 12 Container emptying
- 13 Filter cartridge replacement
- 14 Filter cartridge regeneration
- 15 Central power unit disposal
- 15 Central power unit inspection
- 16 Troubleshooting

INSTALLATION

- 8 Positioning the central power unit
- 8 Central power unit installation allowances
- 9 Bracket fastening
- 10 Dust inlet line connection
- 10 Exhaust conveyor line connection
- 11 Electrical connection

english

GENERAL WARNINGS

Manual use

The installation, user and maintenance manual is an integral and essential part of the central power unit and must be read carefully as it contains important information concerning operator safety, foreseen operation and the correct maintenance of the central power unit.

Liability

The central power unit must only be implemented for the use for which it was explicitly designed (see paragraph FORESEEN USE).

Any other use is considered incorrect and therefore dangerous (see paragraph INCORRECT USE).

The central power unit should not be used by people with reduced physical, sensorial or mental capacities, by children or by people without product experience or knowledge, unless they are supervised or have been instructed in the use of the central power unit by a person responsible for their safety.

The manufacturer shall not accept any contractual and extra contractual liability due to damage caused by errors in using and installing the central power unit or due to failure to observe the instructions provided by the manufacturer.

NOTE

AERTECNICA reserves the right to modify the product and the related technical documentation without incurring any obligation to third parties.

No part of this manual may be reproduced, copied or distributed in any manner without written authorisation from AERTECNICA.



This manual is printed on 100% recycled paper

WARRANTY

Warranty conditions for EEC countries

AerTECNICA guarantees the proper operation of the purchased central power unit for a 24 month period starting from the documented purchase date.

If there is not any documentation that proves the purchase date (invoice or fiscal receipt), the 24 month period will refer to the date it was sold by AERTECNICA.

The warranty conditions are those provided by current European legislation and in any case the following are not covered by the warranty:

Faults, damage or breakage caused by incorrect electric connection during or after installation.

Faults, damage or breakage caused by the malfunctioning of other components in the system, (e.g., vacuum sockets), if these components are not from AERTECNICA.

Faults, damage or breakage caused by pipe clogging.

Faults, damage or breakage caused by carelessness, negligence, inability or incorrect use.

Materials, components and accessories, including electric and electronic ones, when the damage is not related to original manufacturing defects or when the damage is due to component wear.

The warranty will lapse in the case of tampering, repairs carried out by unauthorised individuals or when non-original spare parts are used.

Other additional warranty conditions will only and exclusively be the responsibility of the party proposing them.

For all disputes, the court of Forlì-Cesena (Italy) shall have exclusive jurisdiction and Italian legislation shall apply.

EXTRA EEC warranty conditions

For countries that are not part of the EEC, the warranty shall be the responsibility of the importing company and the warranty conditions shall be those foreseen by the applicable regulations in the country of export.

SAFETY

This sign is used in the manual to point out all operations that must be strictly followed to guarantee personal safety as well as the safety of others and the central power unit.



HAZARD: this indicates that attention must be paid in order to prevent events that could cause serious accidents that harm people or their health.



HAZARDS OF AN ELECTRIC NATURE: make sure that the central power unit is connected with the relative cable to a standard compliant earthing system. Complete disconnect the voltage from the central power unit for maintenance operations.

english



CRUSHING HAZARD: when handling and installing the central power unit it is recommended to use suitable equipment for lifting and securing it to prevent the central power unit from falling accidentally.



HAZARD OF DAMAGING THE CENTRAL POWER UNIT: follow the provided instructions for use to prevent consequences that could damage the central power unit.



INHALATION OF HARMFUL ELEMENTS AND DUST: protect respiratory organs by using protective masks when emptying the dust containers and when replacing the filter cartridge so the collected dust is not inhaled.



DUST SENSITIVITY: this means that hand protection must be used to prevent harming operators who are sensitive to the collected dust.

CERTIFICATIONS

Aertecnica S.p.A is a company certified with:



Quality system
UNI EN ISO 9001
Environmental management system
UNI EN ISO 14001



Product certification for the single-phase power unit range for the residential market sector, series:



STUDIO TS

IDENTIFICATION

This user and maintenance manual is an inherent part of the central power unit:

SERIES: STUDIO TS
MODELS: TS1 - TS2 - TS4

MANUFACTURER

AERTECNICA S.p.A.
Via Cerchia di Sant'Egidio,760
47521 Cesena (FC) ITALY
Tel. +39 0547/637311
Fax +39 0547/631388
info@aertecnica.com
www.aertecnica.com

Technical Service

The Technical Service Centre can be contacted for all technical problems and in order to request spare parts. For all communications concerning the central power unit, the user should always provide the following data:
central power unit model
serial number
year of manufacturing
date of purchase and a detailed description of the discovered problems.

When replacing the central power unit's spare parts it is recommended to use original spare parts; AERTECNICA declines all liability concerning decreased performance or damage to the central power unit due to the use of non-original spare parts.

IDENTIFICATION PLATE

For these models, the identification plate is located on the body of the central power unit as shown in the figure.

The necessary identification data are:
model, serial number and year of manufacturing.

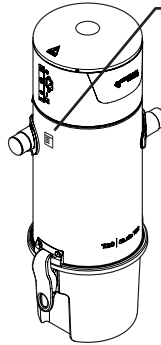

TUBÒ		AerTECNICA S.p.A. via Cerchia di S. Egidio 760 47521 Cesena - FC ITALY
Mod.	: TS2	
Serial n°	: TS00100	
Year	: 2010	
Volt	: 220/240	
Hz	: 50-60	
~	: 1	
W	: 1600	
 "TS00100"		

DESCRIPTION OF THE TUBÒ VACUUM SYSTEM

The purchased central power unit is the main component of TUBÒ, AERTECNICA's advanced vacuum system.

The TUBÒ system consists of the central power unit, vacuum sockets installed in the building's walls, the hose that is inserted in the vacuum sockets based on the room to be cleaned and a set of cleaning accessories suitable for all residential needs.

A network of plastic pipes installed under the floor and in the walls of the building form the dust intake line that is connected to the central power unit.

The collected dust reaches the central power unit; the large dust particles fall into the collection container whereas a filter cartridge retains the suspended dust; the micro dust (invisible to the eye and not filtered by the cartridge) is discharged outside through the air exhaust line, guaranteeing home hygiene and preventing the dust from recirculating in homes.

The system can reach all areas of the home, both inside as well as outside depending on the position of the vacuum sockets installed in the building. The recommended hose is 9 m. long, which makes it possible to cover a circular area of approx. 40 m² (a reduction in the radius of the circumference is due to obstacles in the room (furniture) that make it necessary for the tube to follow a curved path).

The dust container must be emptied periodically (approx. 2-3 times a year; see paragraph CONTAINER EMPTYING). The filter cartridge should be replaced with a new one every 2-3 years (based on its use; see paragraph FILTER CARTRIDGE REPLACEMENT).

The filter cartridge can be regenerated by washing it periodically (based on its use; see paragraph FILTER CARTRIDGE REGENERATION).

These timescales are approximate for normal vacuum system use. In the case of intense use of the system and a large amount of vacuumed dust, the timescale will be shortened.



english

PART DESCRIPTION

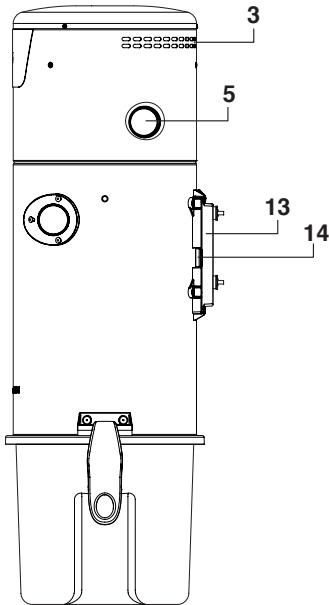

STUDIO TS4

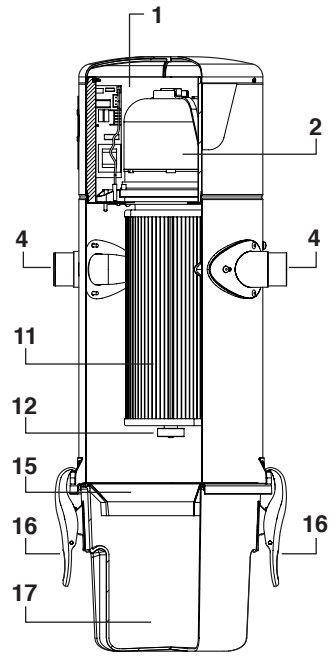

STUDIO TS2

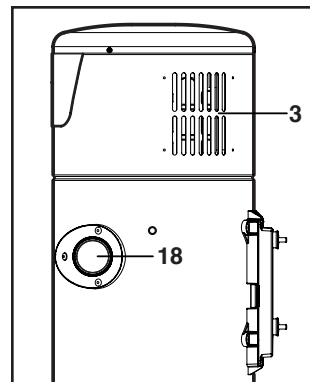
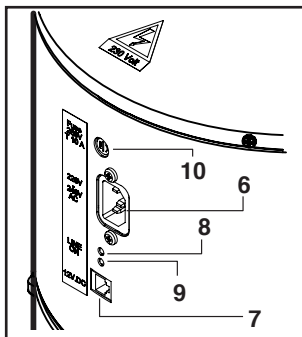

Legend

- 1 - Sound-proofed motor chamber
- 2 - Electric motor
- 3 - Motor air intake
- 4 - Dual right/left dust inlet
- 5 - Air Exhaust line **(only TS4)**
- 6 - Power supply
- 7 - Operation Signal input
- 8 - Green Led On: power unit on
- 9 - Green Led On: power unit running

- 10 - Fuse
- 11 - Filter cartridge
- 12 - Fixing Knob
- 13 - Fixing bracket
- 14 - Locks lever
- 15 - Cone conveyor
- 16 - Ergonomic handles
- 17 - Dust container
- 18 - Dust inlet closing cap

english

TECHNICAL FEATURE

Model		STUDIO TS1	STUDIO TS2	STUDIO TS4
Power supply	Volt (Vac)	220/240	220/240	220/240
Motor power	Watts (W)	1.260	1.600	1.650
Frequency	Hz	50/60	50/60	50/60
Motor rpm	rpm	43.507	46.480	31.014
Turbine stages	n°	1	1	2
SOFT START starting		YES	YES	YES
Socket power supply	Volt (Vcc)	12	12	12
Vacuum power	Air Watts	504	653	690
Max. air flow rate	m ³ /h	207	195	238
Max. vacuum	mbar	270	313	320
Filter cartridge surface	cm ²	4000	8000	8000
Filter cartridge material		POLYESTER	POLYESTER	POLYESTER
Dust container capacity	litres	15	15	23
Height	cm	64	90	103
Diameter	cm	28	28	32
Weight	kg	13	16	18
CMT800 Compatibility		YES	YES	YES
CM8890 Remote Panel Kit Compatibility		YES	YES	YES
CM186 Wireless system Compatibility		YES	YES	YES
Right and left dust inlet		YES	YES	YES
Right air exhaust		YES ¹	YES ¹	YES
Noise	dB	57	55,6	58
Silencer as standard equipment		NO	NO	YES

¹ Exhaust conveyor line with CM640 convey (Optional)

english

HANDLING THE PACKAGING

The central power unit is delivered inside cardboard packaging to make it easier to transport.

It is recommended to not remove the packaging until installation to prevent damaging it.

To lift and transport the central power unit, use the handles positioned on the sides of the packaging (1).

NOTE

 The packaging elements that accompany the central power unit upon delivery are inert solid waste that must be disposed of according to current applicable regulations.

OPENING THE PACKAGING

When opening the central power unit packaging, follow the instructions indicated on the sides of the cardboard box.

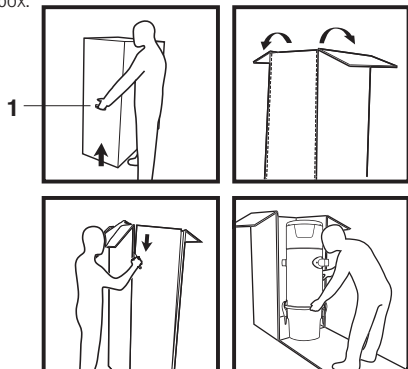

FORESEEN USE

The central power unit was designed exclusively for vacuuming dust or small sized solid bodies.

The dust container must be emptied each time that it is filled.

The filter cartridge must be regenerated periodically and must be replaced every 2-3 years or immediately if it breaks.

When replacing spare parts, use original Aertecnica spare parts.

INCORRECT USE



Use personal protection garments before carrying out operations such as emptying the dust container or replacing/cleaning the filtering cartridge.



english

In order to guarantee proper operation of the central power unit and to prevent the relative warranty coverage from lapsing, follow the instructions provided below:

Do not vacuum lighted cigarettes, hot embers or burning material: these materials may cause a fire to start that would damage the hoses and the central power unit.

Do not vacuum cloths, rags, fabrics or textile material: these materials could obstruct the hoses or damage the central power unit.

Do not vacuum liquids, materials saturated with liquids or very moist materials: these materials could cause the electric system to short circuit, prevent the proper passage of the dust or damage the sockets and the central power unit.

Liquid can be vacuumed using a special accessory (art. AP372; art. AP373).

Do not allow children to play with the vacuum sockets, opening and closing them continuously or inserting toys or solid items of unsuitable dimensions.

Do not vacuum the dust using multiple sockets at the same time (Aertecnica produces central power units that can be used by multiple operators at the same time in the TRIFASE line).

Do not use the system with the central power unit turned on without the filter cartridge inserted.

Do not block the air exhaust line.

Do not block the air sockets for electric motor cooling.

Do not use the cleaning accessories to vacuum parts of the body.

Do not leave the central power unit powered when it is not used for prolonged periods of time.

TURNING ON/OFF

Turning on the centralised vacuum system depends on the type of hose and the installed vacuum socket model.

There are two types of hoses:

TYPE 1: hose with an activator union.

The central power unit turns on when the union (B) is inserted in the vacuum socket (A).

TYPE 2: hose with a switch.

The central power unit is turned on using the switch on the hose itself.

Insert the hose-socket union with the special plates (D) in correspondence of the contacts (E) inside the socket.

To turn off the central power unit:

with the TYPE 1 hose, remove the hose from the vacuum socket (A);

with the TYPE 2 hose, move the switch to the OFF position.

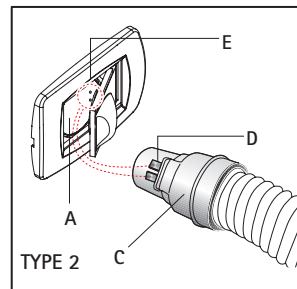
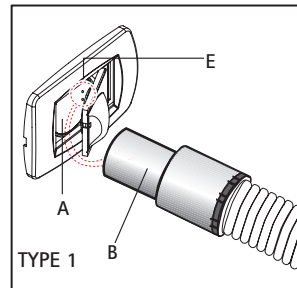

CENTRAL POWER UNIT POSITIONING

The central power unit is installed in service rooms (for example, store-rooms, garages, cellars) that are aired and protected from extreme temperature changes.

The installation area must be sufficiently spacious and well-lit to be able to replace the filter cartridge and the dust container.

The 220/240 power supply line and the vacuum socket consent line for activating the centralised vacuum system must be prepared near the central power unit.

The following table specifies the main reference allowances for correct central power unit installation.

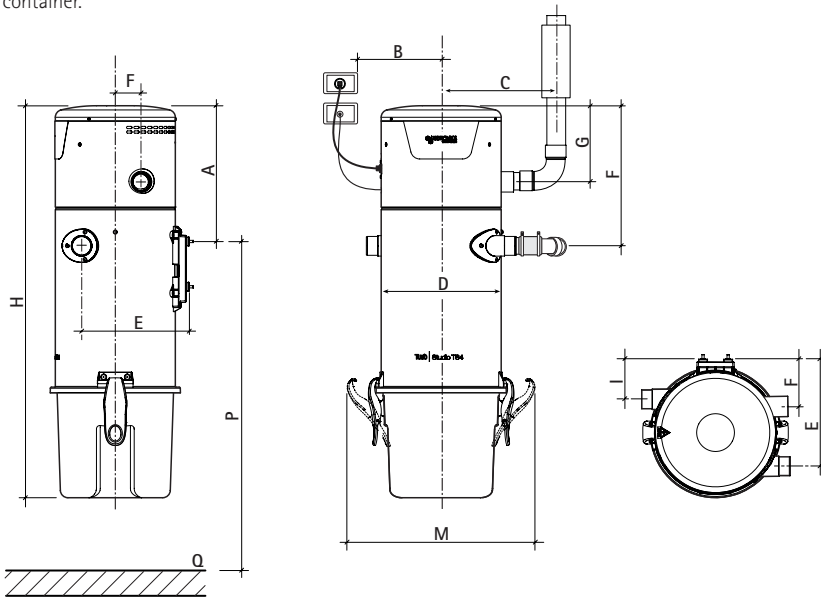

english

STUDIO TS INSTALLATION ALLOWANCES (in mm.)			
	STUDIO TS1	STUDIO TS2	STUDIO TS4
A	143	298	360
B	400	400	350
C	330	330	260
D	280	280	320
E	270	270	290
F	314	321	370
G	124	124	200
H	650	900	1038
I	250	250	285
L	90	90	120
M	47	47	51
P	1500	1400	1400
Q	floor level	floor level	floor level

BRACKET FASTENING

1A - WITH WALL STIRRUP

Fix the stirrup to the wall

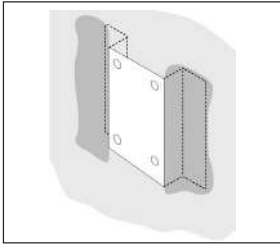

1B - WITH SCREW ANCHORS M6 Ø12

Drill. Using a water level, check that the fixing is level with the wall.

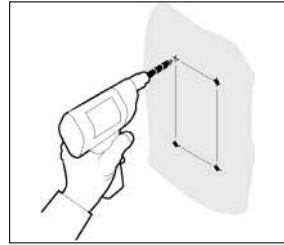

2 - Shift the locking lever

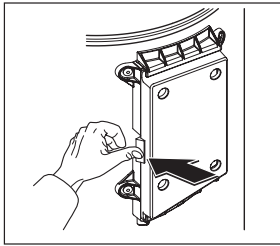

3 - Pull off the support from the guides 4 - Fit the vibration blocks to the support

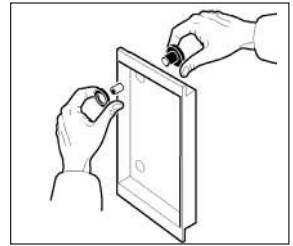
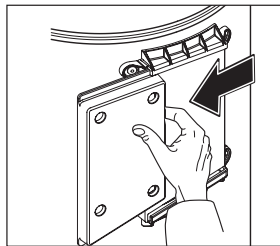

english

5A - WITH WALL STIRRUP

Fasten the bracket to the wall using the supplied screws

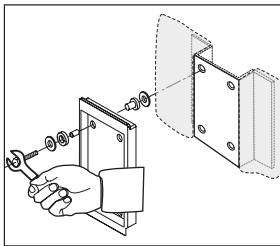

5B - WITH SCREW ANCHORS

Fix the support using proper anchors (not included)

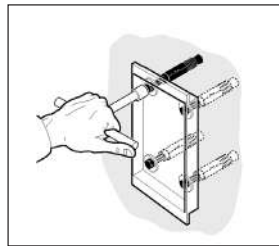

6 - Remove the dust container

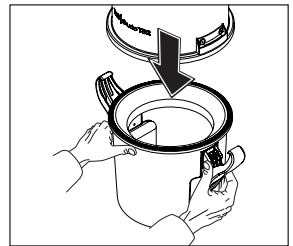

7 - Secure the power unit to the support

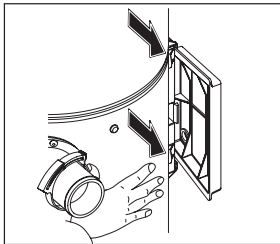

8 - Make sure the locking lever locks in position

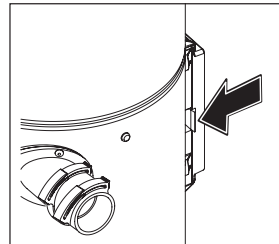

9 - Refit the dust container

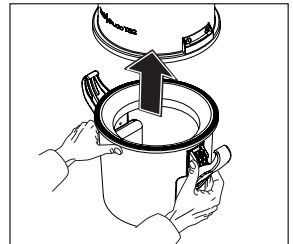

CONNECTION DUST INLET LINE

All of the central power units have a dual dust inlet to permit the connection of the socket line hose on both sides of the central power unit, making installation easier.

Select the most convenient central power unit dust inlet to connect the dust inlet line

Check that the dust inlet not in use is closed. Place the provided pressure cap (T).

SLEEVE MOUNTING

Assemble the rubber sleeve (M) on the dust inlet using the two provided clamps (F) and connect it to the inlet hose.

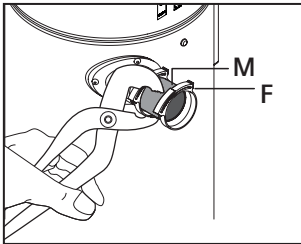

AIR EXHAUST CONNECTION

It is recommended to install an exhaust hose that is no longer than 5 metres.

If the exhaust line is longer, use a hose with a diameter of $\varnothing 63$ or larger and install a silencer of a suitable diameter. Always position the silencer near the exhaust grille.

AIR EXHAUST LINE COMPONENTS

- 1 - silencer $\varnothing 100$
- 2 - conical increase $\varnothing 50F - \varnothing 80F$
- 3 - exhaust grille $\varnothing 80$
- 4 - outlet hole $\varnothing 82$

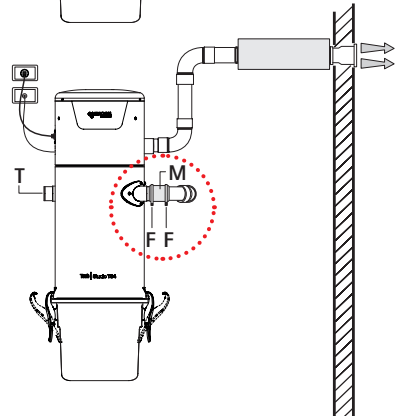
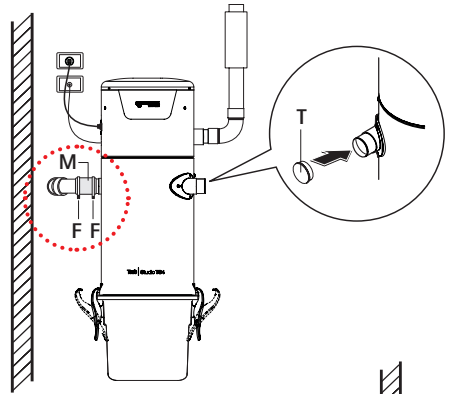
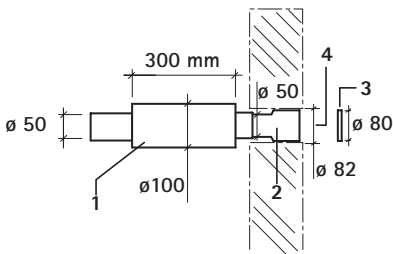

english

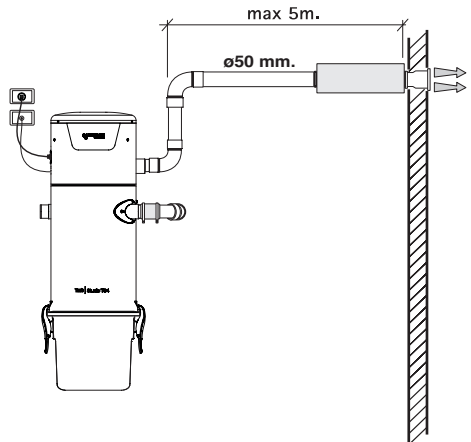

ELECTRICAL CONNECTION



DANGER OF ELECTROCUTION

Make sure that the electric line is dimensioned to support the central power unit power and check that the mains network corresponds to the voltage specified on the identification plate.

CONNECTION OF THE CENTRAL POWER UNIT TO THE POWER SUPPLY LINE

The power supply cable (8) with Schuko plug (7) for the central power unit is supplied as standard equipment with the central power unit.

CONNECTION OF THE CENTRAL POWER UNIT TO THE SOCKET LINE

A socket cable connection (3) is supplied.

english

To make the socket line connection, wire the central power unit connection cable as shown at the (5) number.

GENERAL COMPONENTS

- 1 - pre-wired sheathing 2x1 ø16 for socket line 12v
- 2 - electric junction box
- 3 - 12v socket cable line
- 4 - 12v signal input
- 5 - connection of 12v socket line with socket cable
- 6 - 220/240V power outlet
- 7 - Schuko plug
- 8 - Electrical cable
- 9 - Power supply
- 10 - Socket frame

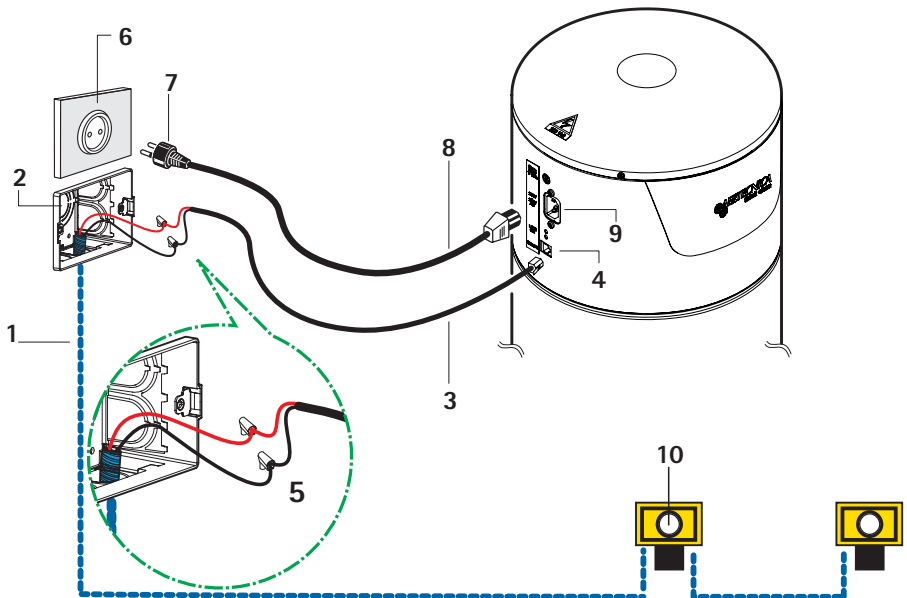

The central power unit electric power supply system must be installed by qualified personnel in compliance with current applicable regulations.

The manufacturer declines all liability for poor operation or damage to people and/or property due to connection to a non-compliant electric system

NOTE



ELECTRICAL DANGER

If the power supply cable is damaged, it must be replaced by AERTECNICA or its Technical Service Centre or in any case by a specialised technician in order to prevent all electrical hazards.

MAINTENANCE

Careful maintenance prolongs the life-time of the central power unit and guarantees better performance.

NOTE



Before starting with any maintenance operation, disconnect the central power unit from the power supply.



The central power unit must not be operated without the filter cartridge inserted. Failure to observe this rule could cause damage to the motor that is not covered by the warranty.

CONTAINER EMPTYING

1 - Rotate both handles upwards simultaneously and remove the dust container

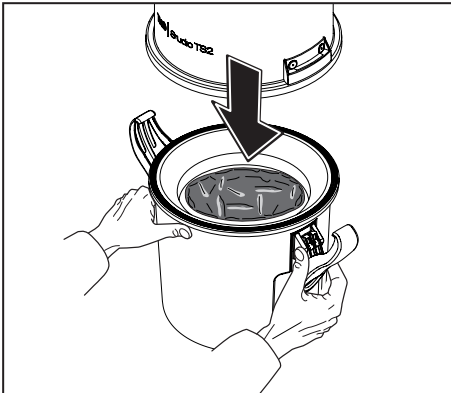

2 - Lift out the conveying ring

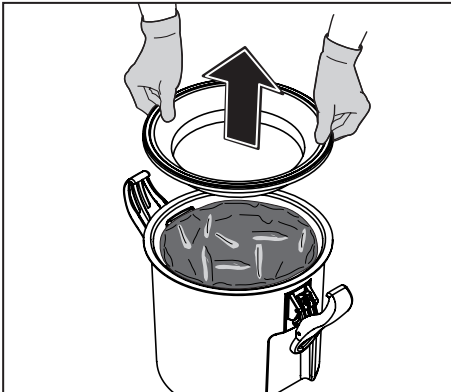

3 - Empty the dust container

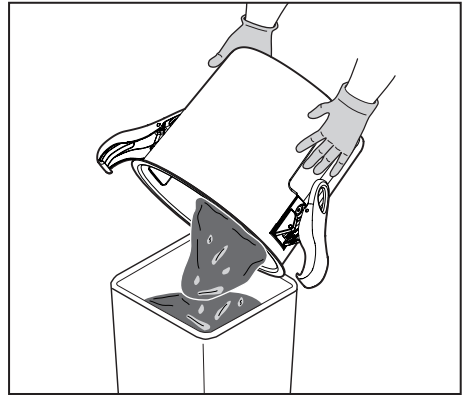

4 - Reassemble the dust container paying attention to the seal position (G) and close the handles.

english

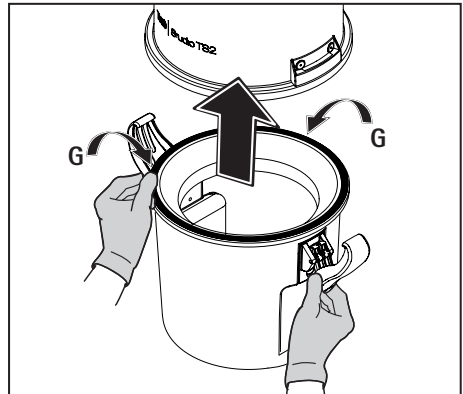

FILTER CARTRIDGE REPLACEMENT



Before starting with any maintenance operation, disconnect the central power unit from the power supply.

It is recommended to replace the filter cartridge every 2-3 years.

This period may change depending on the degree of system use.



ATTENTION

When carrying out this operation, it is easy to come into contact with the dust collected on the cartridge walls.



Before removing the filter cartridge, it is recommended to wear suitable personal protective garments.



english

1 - Open the dust container rotating the handles (M)

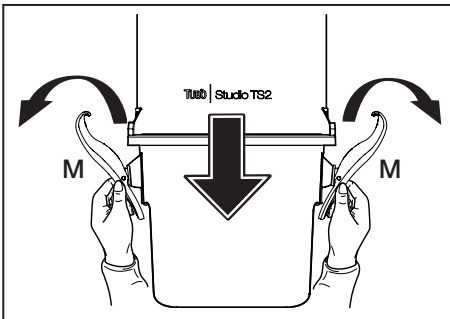

2 - Unscrew the knob (P) that fastens the cartridge (C) and remove it from its housing

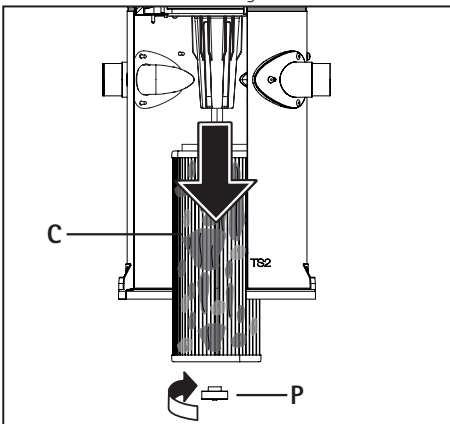

3 - Insert a new cartridge (N) and tighten the knob (P).

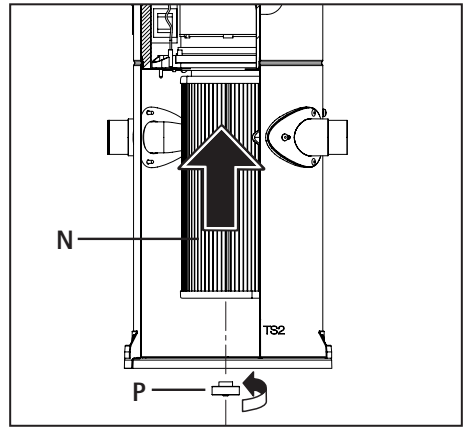

4 - Rehook the dust container and close the handles (M).

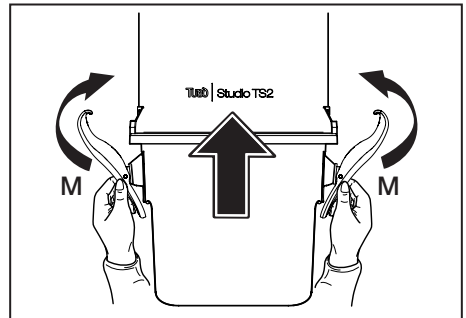

NOTE

The central power unit must not be operated without the filter cartridge inserted. Failure to observe this rule could cause damage to the central power unit motor.



USE ONLY ORIGINAL AERTECNICA SPARE PARTS

FILTER CARTRIDGE REGENERATION (for all central power unit models)

Periodic filter cartridge regeneration improves overall centralised vacuum system productivity.
With normal system use, the cartridge should be checked every 4 months.

NOTE

To effectively regenerate the saturated cartridge and keep the centralised vacuum system operating, it is recommended to insert a new filter cartridge immediately, restart the system and vacuum the largest dust particles from the saturated cartridge using the system itself.



ATTENTION

When carrying out this operation, it is easy to come into contact with the dust collected on the cartridge walls.



Before removing the filter cartridge, it is recommended to wear suitable personal protective garments.



NOTE

The central power unit must not be operated without the filter cartridge inserted. Failure to observe this rule could cause damage to the central power unit motor.



**USE ONLY ORIGINAL AERTECNICA
SPARE PARTS**

1 - Vacuum the dust collected on the saturated cartridge walls using the system itself.



2 - After an initial brief cleaning, wash the filter cartridge with a jet of water that is not too strong and remove the dust that penetrated between the walls.



3 - Allow the cartridge to dry completely

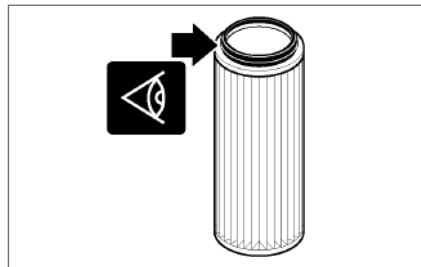

4 - Make sure that there are not any tears or cuts on the cartridge walls. In this case the damaged cartridge must be replaced with a new one.

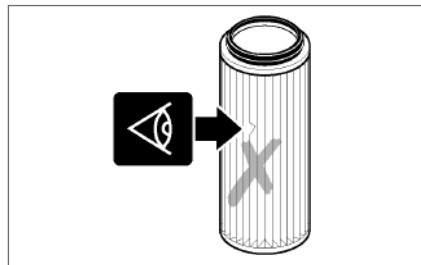

CENTRAL POWER UNIT DISPOSAL (for all central power unit models)

At the end of its life cycle, the machine must be disposed of in compliance with current applicable regulations.

The following table specifies the material with which the central power unit is built.



IMPORTANT

The material listed below must be divided and stored to be recycled or disposed of in compliance with the environmental regulations valid in the country of use.

TYPE OF MATERIAL	PRESENCE IN	SPECIFICS	DISPOSAL
PLASTIC AND RUBBER	dust container	30% talc filled polypropylene	The regulations that govern the disposal and demolition of the central power unit, its components and the possible polluting material and substances change depending on the country of final use.
	cup, tangential openings	polypropylene	
	under motor gasket	thermoplastic rubber	
	motor ring	nylon	
	filter cartridge	poliestere + ABS	
	fixing bracket	nylon 30% caricato vetro	
	antivibration bracket	rubber	
	rubber sleeves	SBR/NR rubber	
	fastening bracket	nylon	
	adhesives	PVC	
	hooks, handles	nylon	
GALVANISED COMPONENTS	gaskets	mousse e pivilene	It is recommended to contact authorised organisations and agencies and to respect the current applicable legal regulations
	silencer	polystyrene	
GALVANISED COMPONENTS	screws and rivets	galvanized steel	
WINDINGS	electric motor and wiring	copper	
ELECTRICAL COMPONENTS	electronic card	misc material	
	turbine motor	misc material	
	led	misc material	
	electric wires	rcopper	
	socket cable line	copper	
	schuko plug	copper	
METAL COMPONENTS	upper body	painted steel	
	clamps and pivots	galvanized steel	
PACKAGING	box	cardboard	
	interpads	cardboard	
	bags	polyethylene	

CENTRAL POWER UNIT INSPECTION

The general centralised vacuum system inspection must be done after the final assembly of all vacuum sockets and the selected central power unit.

CHECK 1

Activate the central power unit with all sockets closed, jumpering the 12V socket line.

Inserting the vacuum gauge in the dust inlet that is not used or in any vacuum socket, check the vacuum value obtained by the central power unit, which will stop automatically after 15 seconds. Note the value that was reached (**value 1**).

Disconnect the tubing from the central power unit and insert a vacuum gauge in its place. Activate the central power unit jumpering the 12V socket cable line; check the vacuum value obtained by the central power unit, which will stop automatically after 15 seconds. Note the value that was reached (**value 2**).

Check that the difference between values 2 and 1 does not exceed 15 mbar.

If the value is higher, this means that there are leaks that must be found and repaired.

CHECK 2

Compare value 2 with the vacuum value indicated in the technical features table for the central power unit model that was purchased.

Check that the difference between the two values does not exceed 10% of the table value.

If the value is higher, contact the Aertecnica Service Centre.

NOTE

the values indicated in the table refer to a power supply voltage of 240 V at 50 Hz. If the mains voltage is less, use the following formula: every 10 volt = 10 mbar (example with the TP1 central power unit: 270 mbar at 240 V = 250 mbar at 220 V).

VACUUM TEST – FOR ALL CENTRAL POWER UNITS

- 1 -Insert the hose in the furthest socket and activate the central power unit.
- 2 -Insert the vacuum gauge (AT010) in the socket adjacent to the one occupied by the hose; if the vacuum value is correct (RANGE between 100 and 150 mbar) the hand will point to the green zone. In this case, the test is positive. Otherwise, contact the Aertecnica Service Centre.

TROUBLESHOOTING

PROBLEM	CAUSE	SOLUTION
THERE IS NO AIR INTAKE FROM ALL THE SOCKETS	Power supply cable disconnected	Connect the power supply cable
	12V socket cable line not connected or incorrectly connected	Connect the 12V socket cable line or check the wiring
	The motor overheated. The motor temperature exceeded 80 °C.	Check if the air exhaust line is free or if the two air exhaust openings are blocked. Wait for the motor to cool down. Make sure the filter cartridge is not saturated. In this case, perform maintenance. Wait for the motor to cool down.
	The dust container is not correctly hooked	Rehook the container correctly.
THERE IS NO AIR INTAKE FROM A SOCKET	The microswitch or the electric contacts in a vacuum socket are damaged.	Call a specialised technician.
LOW AMOUNT OF AIR INTAKE	There is clogging in the system	Call a specialised technician.
	The filter cartridge is saturated	Perform cartridge maintenance.
	Multiple vacuum sockets are being used at the same time on the system	The central power unit may only be used by one operator at a time.
	The dust container gasket is damaged or out of position	Check the position of the dust container gasket.
	The air exhaust line is clogged	Check if the air exhaust line is free or if two air exhaust openings are blocked.
	The hose is partially obstructed	Free the obstruction from the hose.
	The cap was not inserted correctly into the dust inlet not being used in the central power unit	Check that the dust inlet that is not being used is closed with the special cap.
THE CENTRAL POWER UNIT ALWAYS REMAINS ACTIVATED EVEN WITH THE SOCKETS CLOSED	The microswitch or the electric contacts in a vacuum socket are damaged.	Call a specialised technician.
THE LED OF THE POWER UNIT IS OFF	The central power unit power supply cable is disconnected	Call a specialised technician.
	The protective fuse burnt out.	Call a specialised technician..
	The electronic card is defective	Call a specialised technician.
Call a specialised technician for other causes that are not covered in this manual		

english

TUBO

the advanced
vacuum system.

It is prohibited to use the device for uses other than those described in this manual.

The descriptions and technical illustrations may change. Aertecnica S.p.A. reserves the right to modify the product and the related technical documentation without incurring any obligation to third parties.

This version of the service manual describes the features relative to the product on the date on which this publication was licensed for printing.

8001203_rev 0-10



AERTECNICA S.p.A.

Via Cerchia di Sant'Egidio, 760
47521 Cesena (FC) - ITALY
Tel. +39 0547 637311
Fax +39 0547 631388
info@aertecnica.com

www.aertecnica.com

